

# Steam System Optimization

Spirax Sarco

Mark McGinn, New York / New Jersey Manager

# SSI Value Statement

The primary goal of Spirax Sarco is to assist our customers with improving the function of their energy systems.

# Spirax Sarco Global Resource

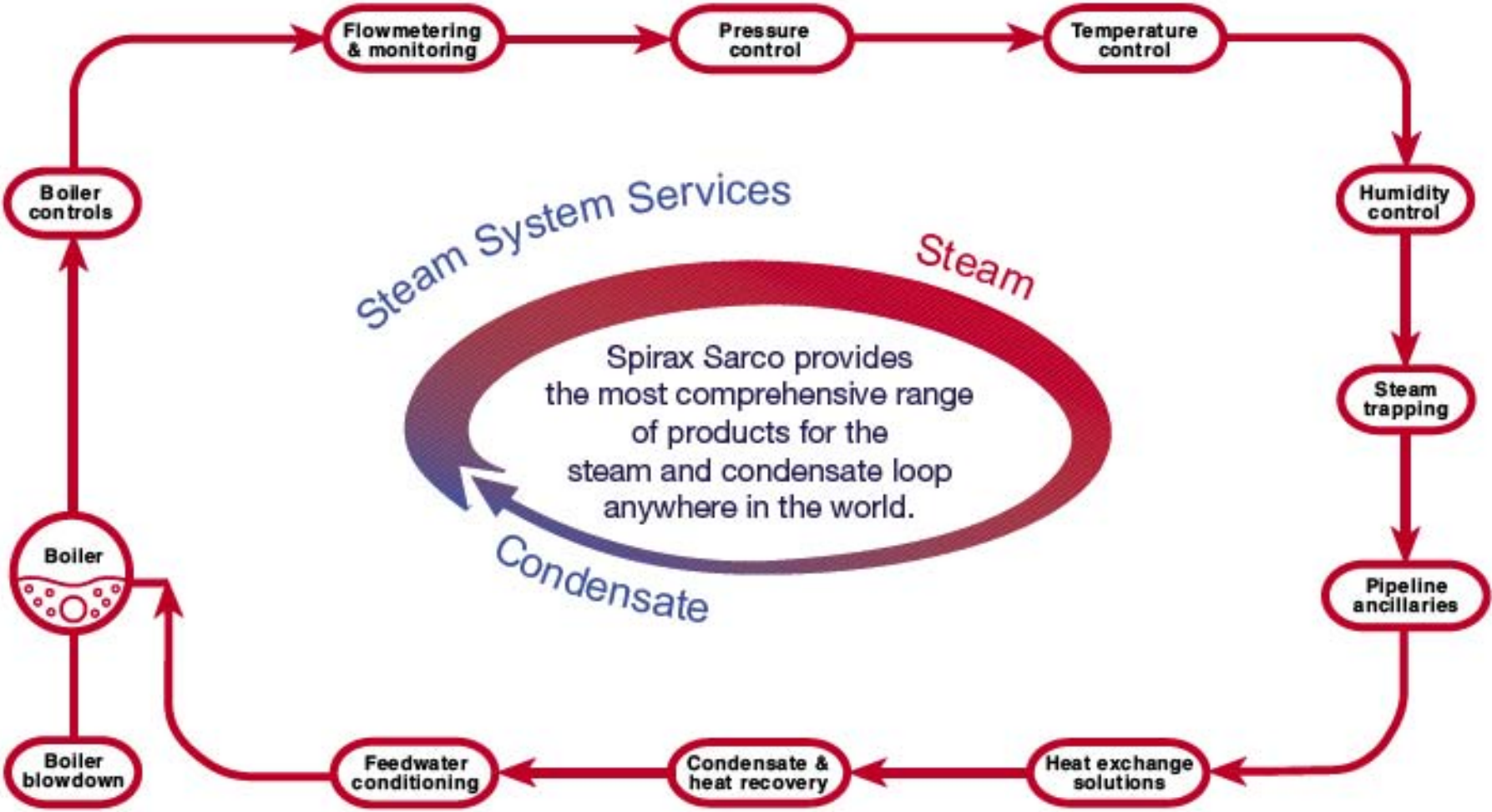

# Product Range

Control systems



Steam traps



Humidifiers

Pipeline ancillaries



Condensate pumps and energy recovery



High purity products



Flowmeters



Boiler controls and systems



# *Save Energy Now ALLY*



- Leverage collaborations and partnerships to expand outreach, resources, and impact
- Build a nationwide network of partners to provide resources and incentives to help industry meet goals

# Save Energy Now ALLY

- Based on ongoing research, ITP is pursuing new ALLY Organizations

- States
- Trade Associations & Allies
- Suppliers & Vendors
- Public officials
- Utilities – gas, electric, water
- Regional Affiliations
- Universities & Colleges
- Federal Agencies
- National Laboratories



# Industry and Energy Use

- The U.S. manufacturing sector consumes **more energy** than any other portion of the economy. Industry represents approximately 32% of total U.S. energy consumption.

**Reducing U.S. industrial energy intensity is essential to achieving national energy and carbon goals**

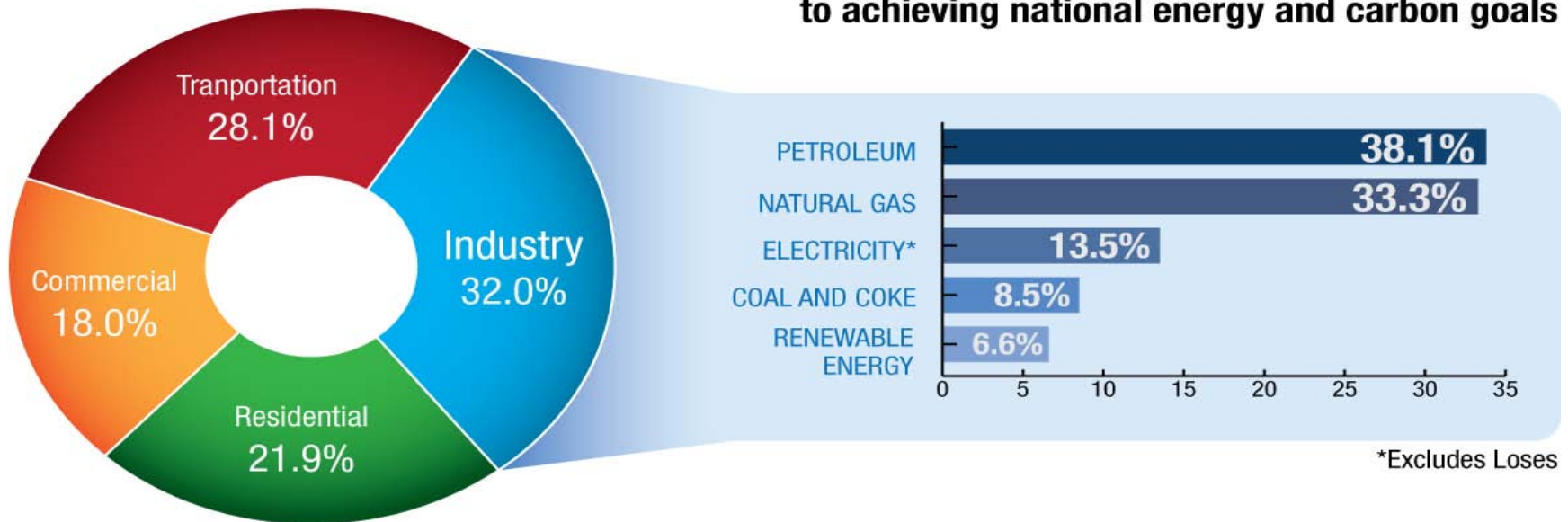

\*Excludes Losses

# Driving Forces for System Optimization!

More Than Just the Cost Of Energy!

# Driving Forces – More Than Just the Cost Of Energy!



# Striving for maximum efficiency

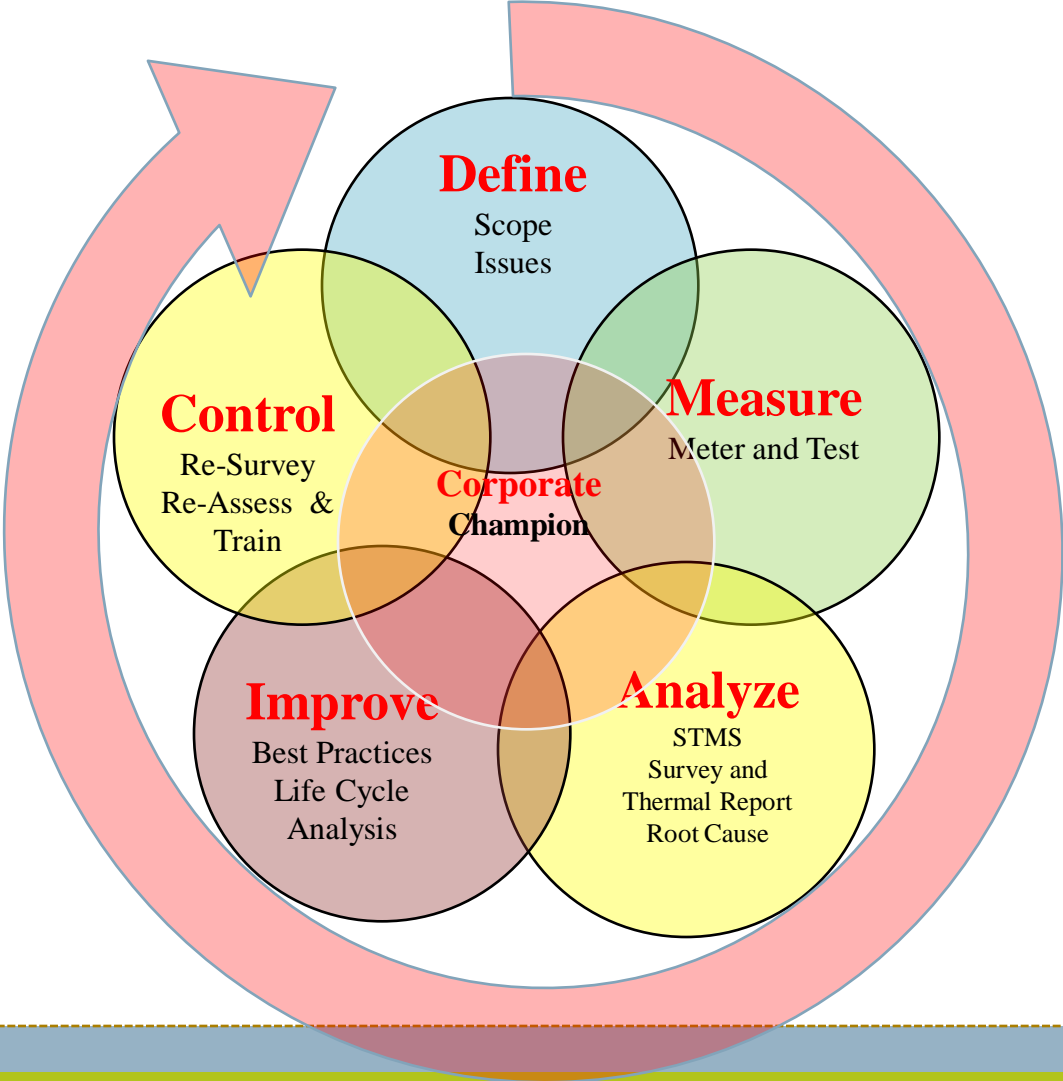

# Prioritized Steps to Optimization :



- **Phase I – Define Goals & Benchmark Critical Utilities**
  - Meter Major Inputs and Outputs
- **Phase II – Analyze**
  - Utilize DOE Fuel Based Software and Other Decision Support Tools
  - Steam Trap Survey
  - Condensate Recovery Evaluation
  - Process Efficiency Evaluation
  - Thermal Imaging Evaluation
- **Phase III - Repairs & Improvements**
  - Complete repairs of both Failed Open and Cold steam traps
  - Insulate Piping and Fittings
  - Repair and Improve Processes and Systems
- **Phase IV – Control**
  - Schedule next survey
  - Train critical Personnel



# Getting To Know Your Plant

## **Measuring, Modeling and Managing Steam Systems**

# Steam System Optimization

## Identify Steam System Losses

### Boiler House

- Boiler Efficiency
- Excess Air & Flue Gas Losses
- Casing Surfaces Losses
- Blowdown Losses

### Steam utilization losses

- Pressure Reduction
- Managing Flash
- Steam Trapping
- Steam leaks

### Distribution losses

- Poor or lack of insulation
- Dead end lines

### Condensate Return

- Condensate Makeup
- Condensate losses: Steam Traps Discharging to drain
- Flash Steam Losses
- Feed Tank Flash Steam Losses. Spray Condensing

# Energy Balance

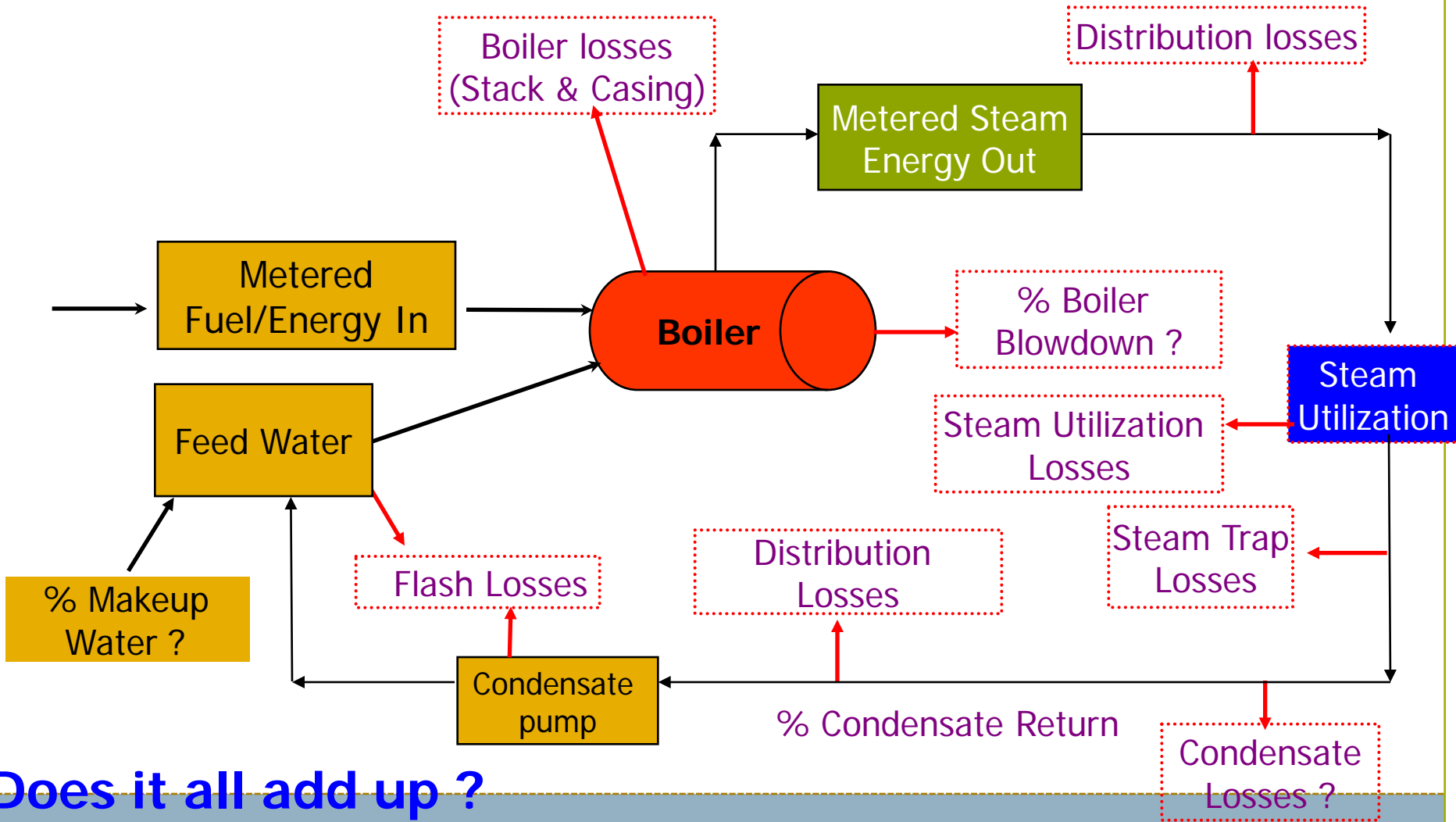

Does it all add up ?

# Minimum Required Measurements

- Fuel Flow and Totalizer
- Steam Flow to Process and Totalizer
- Highly Recommended Measurements are Makeup Water, feed water and Condensate Return
- Boiler Cycles of Concentration: Water Treatment Specialist

# Steam System Optimization

## Steam “Best Practice” System Modeling Tools

- Steam System Scoping Tool (SSST):
  - Used to perform initial self assessments to profile and grade existing steam system operations and management against BestPractices.
- Steam System Assessment Tool (SSAT):
  - Used to develop approx. real steam system models. Quantifies the magnitude-energy, cost, and emissions savings of key potential steam system improvement opportunities.
- 3E Plus
  - Calculates the most economical thickness of industrial insulation for existing operating conditions.

# Steam System Optimization

## Steam System Scoping Tool (SSST)

- Used to develop a greater awareness of opportunities to improve existing steam systems
- Compares existing steam system operations to those from other facilities

STEAM SYSTEM SCOPING TOOL, Version 1.0d

6/12/2002

### STEAM SYSTEM PROFILING

#### STEAM COSTS

**What To Do** Identify what it costs at your facility to produce steam (in units of \$/1000 lbs), and use this as a benchmark for evaluating opportunities for improving your steam operations. Start with determining what your fuel costs are to make steam, then add other costs associated with your operations (chemical costs, labor, etc).

**Why Important** Understanding the cost to make steam can be an eye-opener - producing steam is not free! Any opportunity that reduces the amount of steam generated saves money, so understanding the cost to make steam is a key step to being able to quantify improvement opportunities.

		ACTIONS	SCORE	YOUR SCORE
SC1	Do you monitor your Fuel Cost To Generate Steam - in terms of (\$) / (1000 lbs. of steam produced)?	yes	10	[ ]
		no	0	
SC2	How often do you calculate and trend your Fuel Cost To Generate Steam?	at least quarterly	10	[ ]
		at least yearly	5	
		less than yearly	0	

#### STEAM/PRODUCT BENCHMARKS

**What To Do** Identify how much steam it takes to make your key products. Then track this benchmark: a) with what other facilities in your company do; b) with what other similar plants in your industry do; and c) with how this benchmark varies in your operations over time.

**Why Important** The bottom line of your operation is how cost effectively you make your products, and steam use has an impact on your productivity. Steam/product benchmarking is an excellent way to monitor productivity and how steam improvements translate to improved productivity.

		ACTIONS	SCORE	YOUR SCORE
BM1	Do you Measure your Steam/Product Benchmark - in terms of (lbs. of steam needed) / (unit of product produced)?	yes	10	[ ]
		no	0	
BM2	How often do you Measure and Trend your Steam/Product Benchmark - in terms of (lbs. of steam needed) / (unit of product produced)?	at least quarterly	10	[ ]
		at least yearly	5	
		less than yearly	0	

# Steam System Optimization

## Steam System Assessment Tool (SSAT)

- **PURPOSE:**
  - Demonstrate the magnitude of energy, cost, and emission savings related to specific steam system improvement opportunities
- **AUDIENCE:**
  - Engineers involved with operation and/or improvement of steam systems

# Steam System Optimization

## You Can Use SSAT To Evaluate These Key Steam Improvement Initiatives

- Real Cost Of Steam
- **Reduced Steam Demand**
- Steam Quality
- **Boiler Efficiency**
- Alternative Fuels
- Cogeneration Opportunities
- Steam Turbines vs PRVs
- Boiler Blowdown
- **Condensate Recovery**
- **Steam Trap Operating Efficiency**
- Heat Recovery
- Vent Steam
- **Steam Leaks**
- **Insulation Efficiency**
- Emissions Calculations

# Steam System Optimization

Developed in conjunction with the US Government DOE and Oak Ridge National Laboratory to assess the impact of energy savings projects on Steam System Modeling with Project Improvements

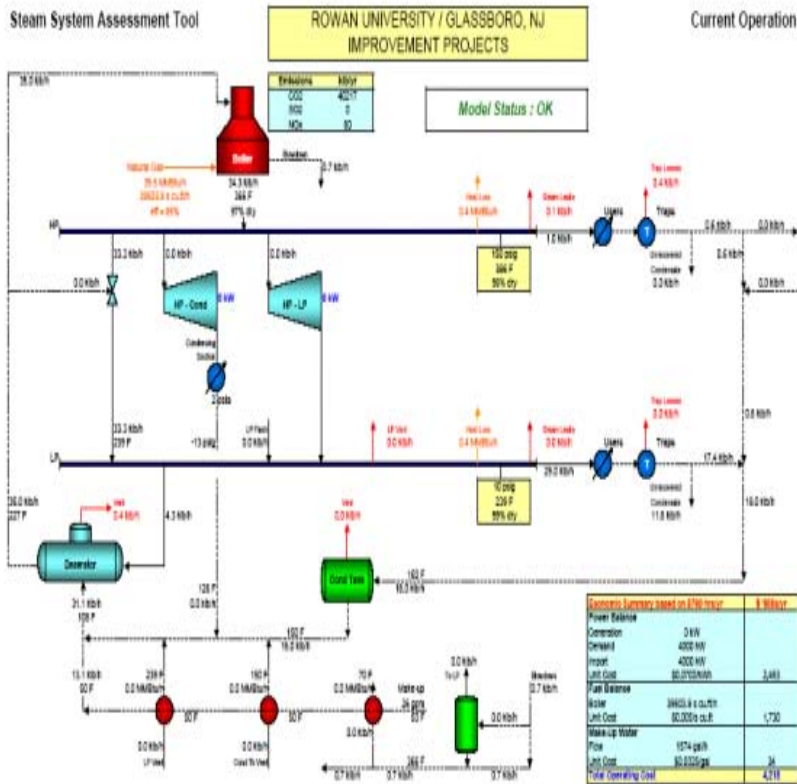

## ROWAN UNIVERSITY / GLASSBORO, NJ IMPROVEMENT PROJECTS

Model Status: OK

Cost Summary (\$ '000s/yr)	Current Operation	After Projects	Reduction	
Power Cost	2,453	2,453	0	0.0%
Fuel Cost	1,730	1,624	106	6.1%
Make-Up Water Cost	34	17	18	51.6%
<b>Total Cost (in \$ '000s/yr)</b>	<b>4,218</b>	<b>4,093</b>	<b>124</b>	<b>2.9%</b>

On-Site Emissions	Current Operation	After Projects	Reduction	
CO2 Emissions	40217 kib/yr	37744 kib/yr	2473 kib/yr	6.1%
SOx Emissions	0 kib/yr	0 kib/yr	0 kib/yr	0.0%
NOx Emissions	80 kib/yr	75 kib/yr	5 kib/yr	6.1%

Power Station Emissions	Reduction After Projects	Total Reduction
CO2 Emissions	0 kib/yr	2473 kib/yr
SOx Emissions	0 kib/yr	0 kib/yr
NOx Emissions	0 kib/yr	5 kib/yr

Note - Calculates the impact of the change in site power import on emissions from an external power station. Total reduction values are for site + power station

Utility Balance	Current Operation	After Projects	Reduction	
Power Generation	0 kW	0 kW	-	-
Power Import	4000 kW	4000 kW	0 kW	0.0%
Total Site Electrical Demand	4000 kW	4000 kW	-	-
Boiler Duty	39.5 MMBtu/h	37.1 MMBtu/h	2.4 MMBtu/h	6.1%
Fuel Type	Natural Gas	Natural Gas	-	-
Fuel Consumption	39503.8 s cu.ft/h	37074.6 s cu.ft/h	-	-
Boiler Steam Flow	34.3 kib/h	32.3 kib/h	2.0 kib/h	5.9%
Fuel Cost (in \$/MMBtu)	5.00	5.00	-	-
Power Cost (as \$/MMBtu)	20.51	20.51	-	-
Make-Up Water Flow	1574 gal/h	763 gal/h	811 gal/h	51.6%

Turbine Performance	Current Operation	After Projects	Marginal Steam Costs
HP to LP steam rate	Not in use	Not in use	(based on current operation)
HP to Condensing steam rate	Not in use	Not in use	HP (\$/kib) 6.70
			LP (\$/kib) 6.70

### List of Selected Projects

- Decrease boiler blowdown rate
- Install blowdown heat exchanger
- Increase HP condensate recovery
- Increase LP condensate recovery
- Steam trap losses maintenance program
- Improve pipework insulation

# Steam System Optimization

## “3E Plus”

- Calculates the most economical thickness of industrial insulation for existing operating conditions.
- Summarizes potential savings in energy costs and emissions

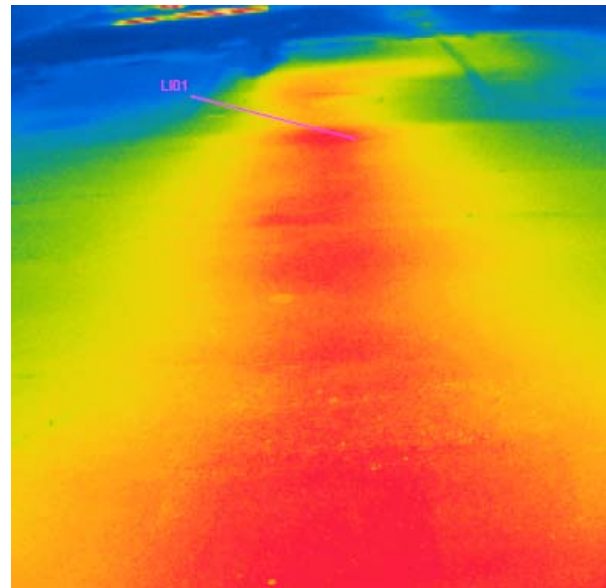
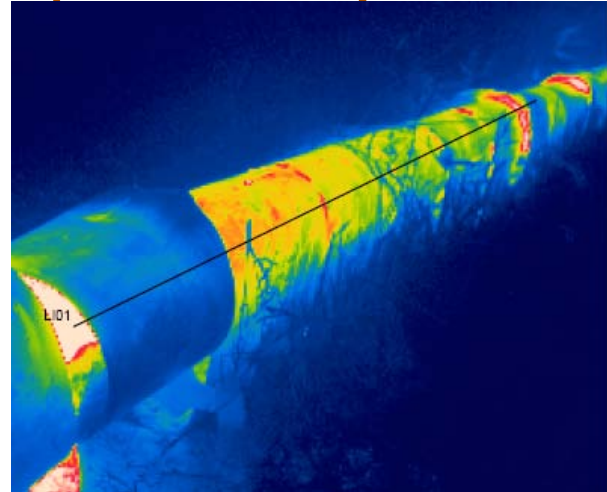

# Steam System Optimization

Steam Trap Survey

# Steam System Optimization

## Steam Trap Management System



**Steam Trap** **STMS**  
Steam Trap Management System

Current Trap Details History

Company	THE XYZ COMPANY	Application	Drip
Site Name	THE XYZ COMPANY	Pressure	150.00 psig
Trap Number	0501	Temperature	185.45 deg C
Location	OLEFINS 1	Suitability	Suitable
Detail		Survey Interval	Annually
Height		Operation	40h/w * 48w/y
Installed	7/22/1998	Test Method	Ultrasonic
Size	3/4" (20mm)	Condition	Failed Open
Model	UTD52L	Last Update	
Con Type	Screwed	Engineer	SSI
Standard	NPT		
Orientation			
Universal Trap	<input type="checkbox"/>		
Diffuser	<input type="checkbox"/>		
Open Ended Trap	<input type="checkbox"/>		
Isotub	<input type="checkbox"/>		
Strainer			
Ancillaries			
Isolation			
Action	None		
Notes			

Automatically add leading zeros to numeric Trap Numbers  Copy current details for new trap

Maintain Survey Copy Help Ok Cancel

Record: 1 of 1



# Steam System Optimization

## Steam Trap Inventory

Trap	Location	Location Detail	Model	Connection Size	Connection Type	Application	Pressure	Condition	Mapping Data		
									Map Number	Height	Drawing Number
0039	ASPHALT CP5	E/ RECOVERY 1 POT	TD52	1" (25mm)	Screwed	Tank Coil	150	Failed Open	3	7'	12204000
0043	ASPHALT CP5	E/ RECOVERY 1 POT	WD600	3/4" (20mm)	Screwed	Tank Coil	150	Failed Open	3	1'	12204000
0044	ASPHALT CP5	E/ RECOVERY 1 POT	WD600	3/4" (20mm)	Screwed	Tank Coil	150	Failed Open	3	1'	12204000
0051	ASPHALT CP5	1ST RACK TRUCK LOAD 3-4	TD52	1/2" (15mm)	Screwed	Drip Utility Station	150	Failed Open	5	3'	12204000
0078	ASPHALT CP5	SW/ TK 24 PIPERACK	WD600	1" (25mm)	Screwed	Tracer	150	Failed Open	10	3'	12204000
0081	ASPHALT CP5	SW/ TK 24 PIPERACK	WD600	1" (25mm)	Screwed	Tracer	150	Failed Open	10	3'	12204000
0084	ASPHALT CP5	SW/ TK 23	TD52	1" (25mm)	Screwed	Drip	150	Failed Open	11	12'	12204000
0088	ASPHALT CP5	S/ TK 24 PIPERACK	TD52	1" (25mm)	Screwed	Drip	150	Failed Open	13	12'	12204000
0092	ASPHALT CP5	N/ TK 33 HIGH RACK	TD52	1" (25mm)	Screwed	Tracer	150	Failed Open	14	12'	12204000
0093	ASPHALT CP5	S/ TK 29	WD600	1" (25mm)	Screwed	Drip	150	Failed Open	15	12'	12204000
0094	ASPHALT CP5	S/ TK 29	TA501	1/2" (15mm)	Screwed	Tracer	150	Failed Open	15	12'	12204000
0113	ASPHALT CP5	E/ TK 34	TD52	1/2" (15mm)	Screwed	Tracer	150	Failed Open	18	1'	12204000
0115	ASPHALT CP5	E/ TK 34	TD52	1/2" (15mm)	Screwed	Tracer	150	Failed Open	18	1'	12204000
0116	ASPHALT CP5	NE/ TK 34	TD52	3/4" (20mm)	Screwed	Drip Utility Station	150	Failed Open	18	3'	12204000
0117	ASPHALT CP5	SE/ TK 121	UNK	1/2" (15mm)	Screwed	Tracer	150	Failed Closed	19	1'	12204000
0119	ASPHALT CP5	SE/ TK 121	SW	1/2" (15mm)	Screwed	Tracer	150	Failed Open	19	1'	12204000
0120	ASPHALT CP5	SE/ TK 121	SW	1/2" (15mm)	Screwed	Tracer	150	Failed Open	19	1'	12204000
0122	ASPHALT CP5	SE/ TK 121	OPT	1/2" (15mm)	Screwed	Tracer	150	Failed Open	19	1'	12204000
0123	ASPHALT CP5	SE/ TK 121	OPT	1/2" (15mm)	Screwed	Tracer	150	Failed Closed	19	1'	12204000
0124	ASPHALT CP5	SE/ TK 121	OPT	1/2" (15mm)	Screwed	Tracer	150	Failed Open	19	1'	12204000
0125	ASPHALT CP5	SE/ TK 121	OPT	1/2" (15mm)	Screwed	Tracer	150	Failed Closed	19	1'	12204000
0127	ASPHALT CP5	SE/ TK 121	OPT	1/2" (15mm)	Screwed	Tracer	150	Failed Closed	19	1'	12204000
0128	ASPHALT CP5	SE/ TK 121	TD52	1/2" (15mm)	Screwed	Tracer	150	Failed Open	19	1'	12204000
0134	ASPHALT CP5	S/ TK 121 AT TANK	OPT	1/2" (15mm)	Screwed	Tracer	150	Failed Open	21	1'	12204000
0136	ASPHALT CP5	S/ TK 121 AT TANK	OPT	1/2" (15mm)	Screwed	Tracer	150	Failed Open	21	1'	12204000
0138	ASPHALT CP5	E/ TK 121	TD52	1" (25mm)	Screwed	Drip	150	Failed Open	20	10'	12204000
0143	ASPHALT CP5	SW/ TK 141 HIGH RACK	TD52	1" (25mm)	Screwed	Tracer	150	Failed Open	22	20'	12204000
0144	ASPHALT CP5	W/ TK 141	OPT	1/2" (15mm)	Screwed	Tracer	150	Failed Closed	22	1'	12204000
0149	ASPHALT CP5	SW/ TK 141	OPT	1/2" (15mm)	Screwed	Tracer	150	Failed Closed	22	1'	12204000
0152	ASPHALT CP5	SW/ TK 141	OPT	1/2" (15mm)	Screwed	Tracer	150	Failed Closed	22	1'	12204000
0153	ASPHALT CP5	SW/ TK 141	OPT	1/2" (15mm)	Screwed	Tracer	150	Failed Closed	22	1'	12204000
0164	ASPHALT CP5	W/ TK 20 M7	OPT	1/2" (15mm)	Screwed	Tracer	150	Failed Closed	27	1'	12204000
0165	ASPHALT CP5	W/ TK 20 M7	OPT	1/2" (15mm)	Screwed	Tracer	150	Failed Closed	27	1'	12204000
0168	ASPHALT CP5	SW/ TK 551	TD52	1/2" (15mm)	Screwed	Tracer	150	Failed Open	28	1'	12204000
0173	ASPHALT CP5	SW/ TK 28	WD600	1" (25mm)	Screwed	Drip	150	Failed Open	30	12'	12204000
0174	ASPHALT CP5	SW/ TK 28	WD600	1" (25mm)	Screwed	Drip	150	Failed Open	30	12'	12204000
0176	ASPHALT CP5	SW/ TK 28	WD600	1" (25mm)	Screwed	Tracer	150	Failed Open	30	12'	12204000
0180	ASPHALT CP5	NW/ TK 5501	OPT	1/2" (15mm)	Screwed	Tracer	150	Failed Open	31	3'	12204000
0186	ASPHALT CP5	NE/ TK 5501	C-42	3/4" (20mm)	Screwed	Drip	150	Failed Closed	33	1'	12204000
0192	ASPHALT CP5	E/ TK 5501	TD52	1" (25mm)	Screwed	Drip	150	Failed Open	33	1'	12204000

# Steam System Optimization

## Overall Survey Results

2007

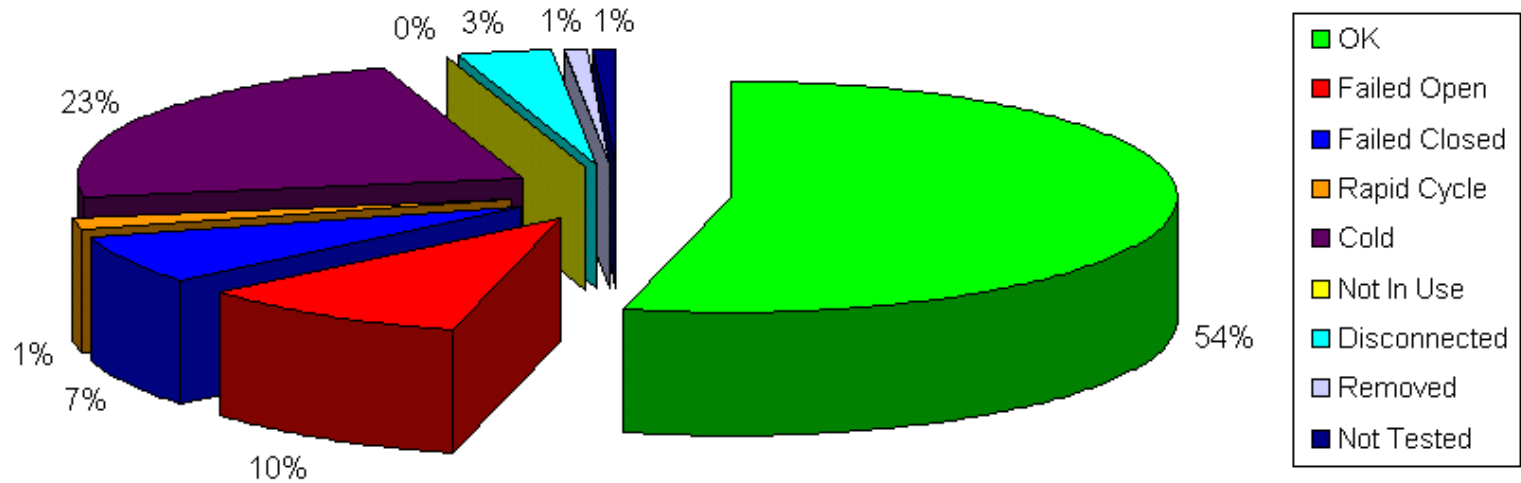

2007

2008

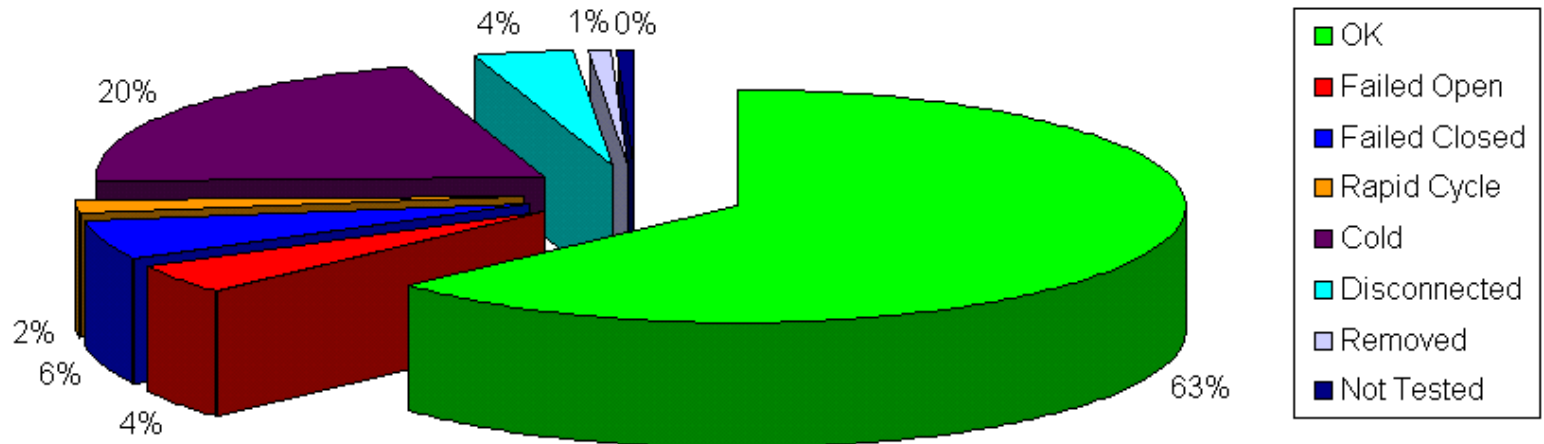

2008

# Steam System Optimization

## CO2 Emissions Reduction

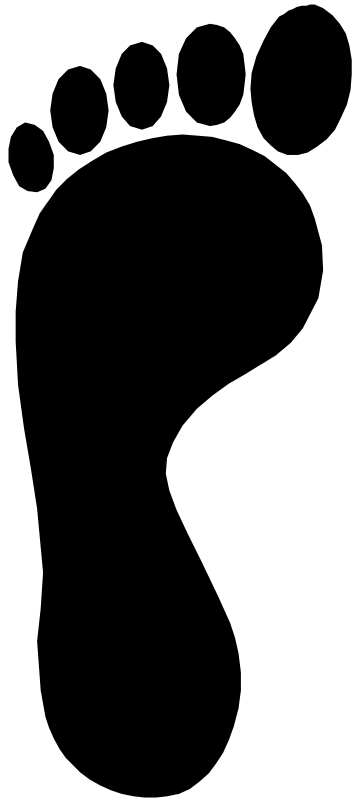

28,517 tons/yr of CO2  
emissions from 669 failed open  
steam traps in 2007

16,376 tons/yr of CO2  
emissions eliminated

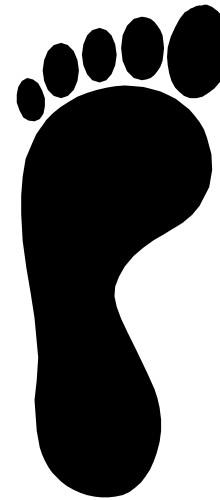

12,141 tons/yr of CO2  
emissions from 351 failed open  
steam traps in 2008

# Steam System Optimization

## \$189K Savings Potential!!!

Recommendation	
Item	Explanation
Implement steam trap maintenance program	<p>Regular steam trap testing, repair and maintenance are critical elements of an efficient production facility. As you will see from the steam trap survey results (separate cover), nearly 60% of the trap population is either failed or cold. Failed open traps are obvious energy losses and are represented in the savings listed below.</p> <p>Traps that are failed closed can present system issues different from failed open traps. Traps that are closed/cold become a collection point for water to accumulate and back up into the steam system. This will create poor steam quality, increased erosion, increased corrosion and increased risk for water hammer.</p>
Location	
All areas	
Savings Potential	
\$ 188.7 K Savings from failed open traps only (see trap survey report under separate cover)	

# Steam Trap TCO

## Drip & Tracer Steam Trap Total Cost Of Ownership Calculator

Managed Service Costs		Required Fields	Site Conditions		Required Fields
Trap cost		\$165.00	Cost/1000/Lbs Steam		\$10.50
Connector		\$145.00	Site Drip & Tracer Trap Population		300
Installation Crew Hours Legacy Trap		2.0	Percent of Failed Open Traps		15%
Installation Crew Hours Replacement Trap		0.5	Percent of Traps Cold / Isolated		3%
Labor Cost Crew / hr		\$125.00	Legacy Trap Failure Rate		10%
Supervision / Engineering per / hr		\$85.00	Ave Trap PSIG 15,30,50,100,150,200,300		100
Per Trap Survey Cost		\$10.00	% Condensate Return		80
Hours required to determine cold trap status		0.6	Plant Operational Hrs/Yr		8000
Annual Survey Frequency		1	Major Trap Type TDL,TD,IB,FT,TH		TD
Spirax Sarco warranty (years)		3	Corporate Cost of Capital		11%
Spirax Sarco Failure Rate After Warranty Period		7%	Percent of Traps not operating correctly		18%
Spirax Sarco During Warrantee failure rate		1%	1000/Lbs Steam loss/failed trap/yr		326
Total install Replacement Trap		\$227.50	Energy Loss / Failed Trap / Year		\$3,427.20
Total install Legacy Trap		\$730.00	Initial Survey Failed Open Traps		45
Cost to Determine Condition of Cold / Isolated Traps		\$51.00	Total Cost Failed Open Traps		<b>\$154,224.00</b>
			Pre Program TCO/Trap		\$514.08
			CO2 Tons/YR Emissions		997
			Make-Up Water GPY		402,745

Year	Annual Energy Loss Avoidance	Legacy Trap Failures	Total Annual Cost	Annual TCO/Trap w/ Program	NPV of Project	IRR	ROI
Original Survey	\$154,224	45	\$35,850	\$377	\$518,760	264%	250%
2	\$44,468	26	\$21,615	\$220	\$140,606	127%	117%
3	\$40,535	23	\$19,754	\$201	\$128,133	127%	117%
4	\$36,996	21	\$18,291	\$184	\$116,744	125%	115%
5	\$33,810	19	\$16,830	\$169	\$106,605	124%	115%
6	\$30,943	17	\$15,930	\$156	\$97,162	121%	111%
7	\$31,200	15	\$15,065	\$154	\$98,732	128%	118%
8	\$31,301	14	\$14,256	\$152	\$99,706	136%	126%
9	\$31,166	12	\$13,500	\$149	\$99,807	142%	133%
10	\$30,835	11	\$12,794	\$145	\$99,177	149%	139%
11	\$30,618	10	\$12,133	\$141	\$98,116	157%	147%

# Steam System Optimization

## COLD Steam Traps

### Pending Disaster :

**26.2 % COLD – 1,620 steam traps which should otherwise be in use are failing to perform their function to remove condensate.**

**Condensate not removed from the steam system results in:**

**Corrosion** - system degradation / leaks

**Waterhammer** - potential safety issue

**Freezing** - pipe ruptures

**All can cause system DOWNTIME and loss of PRODUCTION**



# Steam System Optimization



## Cold Steam Main Drip Traps:

- Waterhammer is extremely dangerous and can be life threatening
- Ruptured Steam Mains cause major plant shutdowns and expensive repairs
- Waterhammer KILLS

**Piece of pipe traveled over WAP Admin Building an estimated 400+ yards, before hitting and bringing down two (2) 345 kV transmission lines and falling in parking lot.**

# COLD Steam Traps Steam System Optimization

NYDAILYNEWS.COM  
**DAILY NEWS**

**Metro News**

NEWS SPORTS ENTERTAINMENT OPINIONS MONEY BOROUGHES LIFESTYLE GOSSIP

Crime File Nation / World Today's Headlines Traffic & Transit NY Minute Columnists Galleries

## Steampipe test shows safety valve was faulty

BY ADAM LISBERG  
DAILY NEWS CITY HALL BUREAU

Thursday, August 16th 2007, 4:00 AM

 Print  Email  Suggest a Story

A crucial Con Edison steam valve wasn't working just before last month's deadly steampipe explosion, a bombshell affidavit from a top state regulator says.

The "steam trap," just feet away from the blast site at 41st St. and Lexington Ave., was supposed to drain water out of the steampipe to prevent a catastrophic condition called "water hammer," which causes water to slam into itself with incredible pressure.

The stainless-steel trap was installed in December 2006, but preliminary tests after the explosion revealed it wasn't operating and had a possible debris buildup, according to the sworn statement by Thomas Dvorsky, an engineer who heads the state Public Service Department office in charge of steam service.

"The nondestructive testing was inconclusive; it just showed the trap assembly was not working properly," Dvorsky wrote.

He said the trap should be cut open to look for "sediment or foreign materials in the trap that prevented functioning."

But a representative for the trap's manufacturer told the Daily News the company believes the valve did not contribute to the blast, because it is designed to fail in a way that releases water.

The affidavit surfaced yesterday in a bitter fight in Brooklyn Supreme Court between lawyers for Con Ed and the family of Gregory McCullough, a tow-truck driver who was badly burned in the July 18 blast and who may lose a leg and an arm.

Con Ed wants to cut open the trap, saying it will record the tests and allow lawyers for those suing the utility to observe. State regulators support that approach.

McCullough's lawyer Kenneth Thompson has blocked the tests, saying the utility can't be trusted to investigate itself.

"I do not want this to happen to any other family," said McCullough's mother, Tanya McCullough-Stewart. "He does cry. You can see the pain in his eyes."



The "steam trap," just feet away from the blast site at 41st St. and Lexington Ave., was supposed to drain water out of the steampipe to prevent a catastrophic condition called "water hammer," which causes water to slam into itself with incredible pressure.

The stainless-steel trap was installed in December 2006, but preliminary tests after the explosion revealed it wasn't operating and had a possible debris buildup, according to the sworn statement by Thomas Dvorsky, an engineer who heads the state Public Service Department office in charge of steam service.



# Steam System Optimization

Steam Leak Survey

# Steam System Optimization

## Identify Steam Leaks

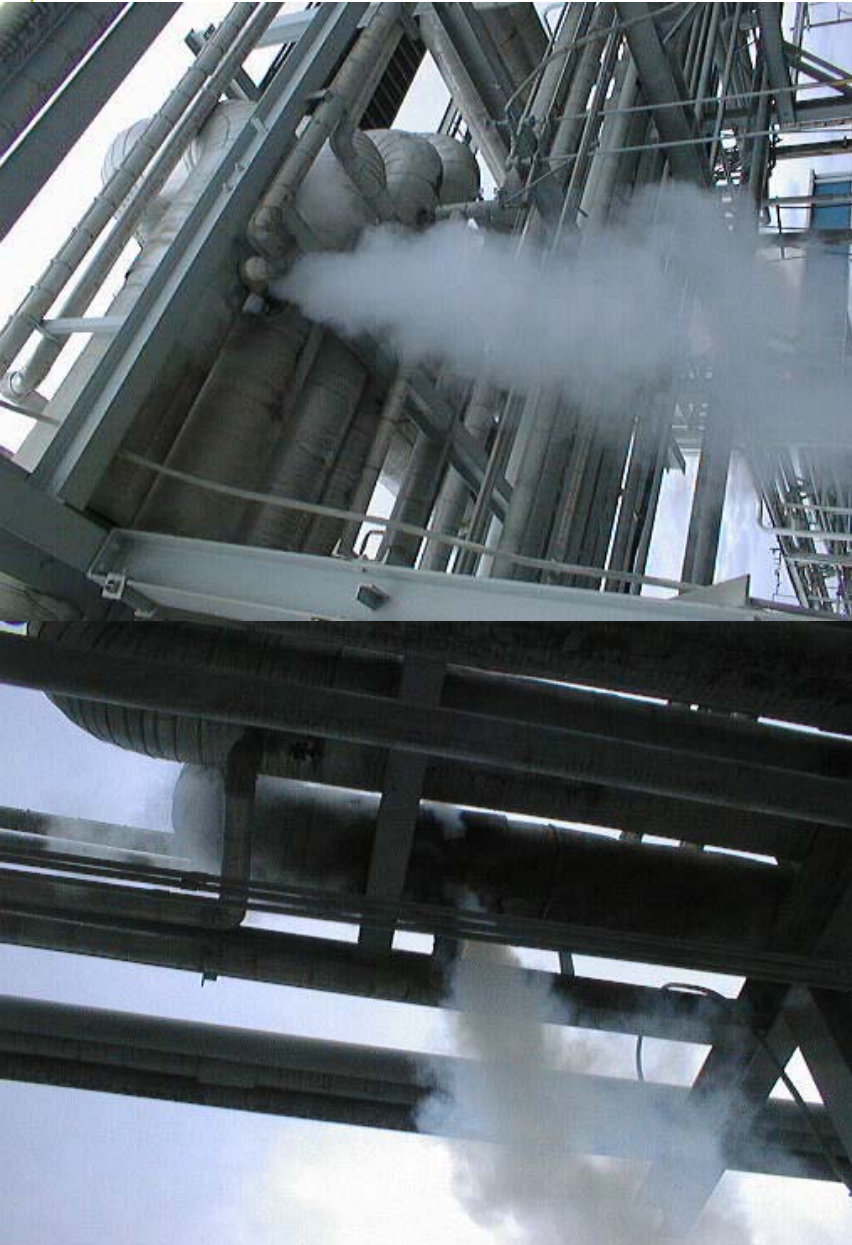

- **Safety**
- **Energy Loss**
  - Causes system degradation
  - Corrosion
  - Vibration / Thermal Shock
  - Impaired System Performance
- Safety
- Safety
- Safety

# Steam System Optimization

## System Improvements



# Steam System Optimization

Thermal Loss Survey

# Steam System Optimization

## Steam Distribution Thermal Survey

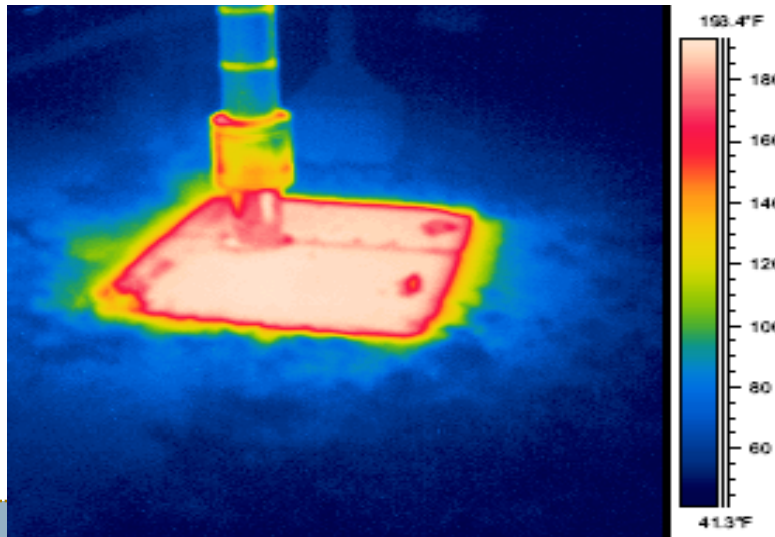
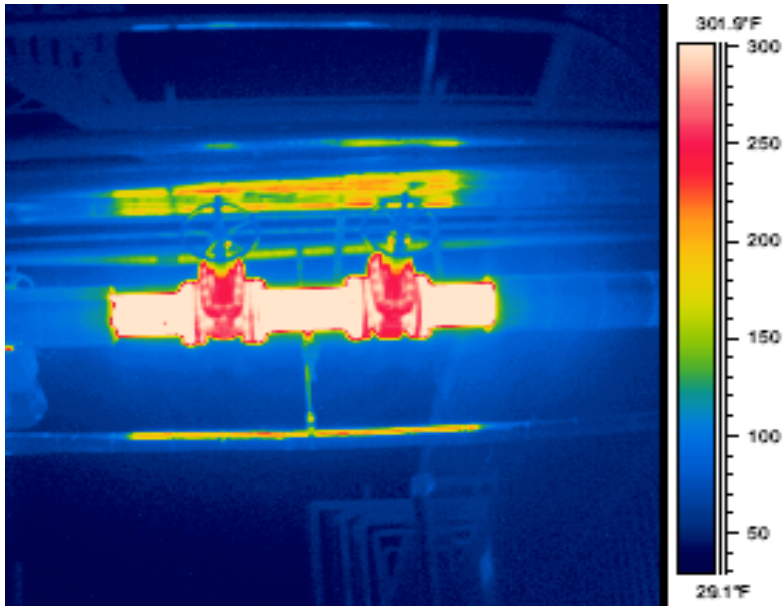

- **Thermal Survey of Steam Distribution Piping with report of BTU loss estimates**
  - 118 locations found
  - 842,000 BTU per hour
- **Log and Mapped (red line) locations**
- **Determine locations that can be repaired or improved**
- **Findings presentation to facility staff**

# Steam System Optimization

Condensate Recovery

# Steam System Optimization

## Condensate Recovery Survey

Condensate Recovery saves:

- Water costs
- Preheating energy costs
- Chemical treatment costs
- Effluent costs
- Boiler Blowdown % (Efficiency)
- Emissions
- Damage to infrastructure
- Safety incidents

**(Just 16 gpm can save over \$123,000.00 per year and 8,400,000 gpy)**



### Condensate Recovery Payback Analysis

#### Instructions:

Input data in white boxes where appropriate:

Do NOT input data in blue boxes:

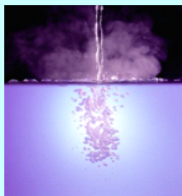

#### Data

Condensate Load	8,000	lbs/hr
Annual Hours of Operation	8760	Hours per year
Raw Water Cost	1.5	\$ per 1000 galls
Sewage or Effluent Cost	0.75	\$ per 1000 galls
Water Treatment Chemicals	1	\$ per 1000 galls
Condensate Return Temperature	190	Deg. F
Make Up Water Temperature	60	Deg. F
Steam Cost	10.00	\$ per 1000 lbs
Boiler Operating Pressure	600	psig
	1203	hg (BTU/lb)
	473	hf (BTU/lb)
Boiler Blowdown	11	%
Cost of Fuel	8.00	\$ per million BTU
Boiler Efficiency	85%	%

#### Additional Information

Maximum Temperature permitted in sewer	140	Deg. F
Is water being used to cool condensate	No	Yes or No

#### Savings

Energy savings in condensate	91,104	\$/year
Make up Water & Treatment Chemical Savings	21,007	\$/year
Sewage/Effluent Cost Savings	6,302	\$/year
Raw Water (cooling) Cost Savings	0	\$/year
Boiler Blowdown Savings	5,013	\$/year
CO <sub>2</sub> Emissions Reduction	621	Tons/year
<b>TOTAL ANNUAL SAVINGS</b>	<b>123,426</b>	<b>\$/year</b>

# Steam System Optimization

## Condensate Recovery



# \$76K Savings Potential

Recommendation	
Item	Explanation
Increase Condensate Return Rate to 45%	Increasing condensate return rate will improve overall efficiency of the system. It will reduce make up water requirements, reduce fuel consumption for pre-heating make up water, reduce sewage costs and reduce boiler blow down rates. Increasing condensate return by a nominal 3,500 lb/hr will provide substantial savings. Itemizing processes that are currently dumping condensate to drain can dramatically reduce total utility costs for the facility.
Location	
Soluble: 6 <sup>th</sup> floor: S and T HE drained w/ by-pass around trap. Large hole eroded through wall	
Bldg 18 Level 3: CT heat exchangers drained by IB traps, dumping to grade	
Rice Level 3: S and T HE w/3' lift after trap, union leaking dumping to grade	
Bldg 18: Dryers dumping condensate to grade	
AMCO 2nd Floor	
Savings Potential	
\$ 76K for an increase from 35 % return rate to 45% (~ 3,500 lb/hr)	

# Steam System Optimization

Flash Recovery



# Steam System Optimization

## Flash Recovery Project

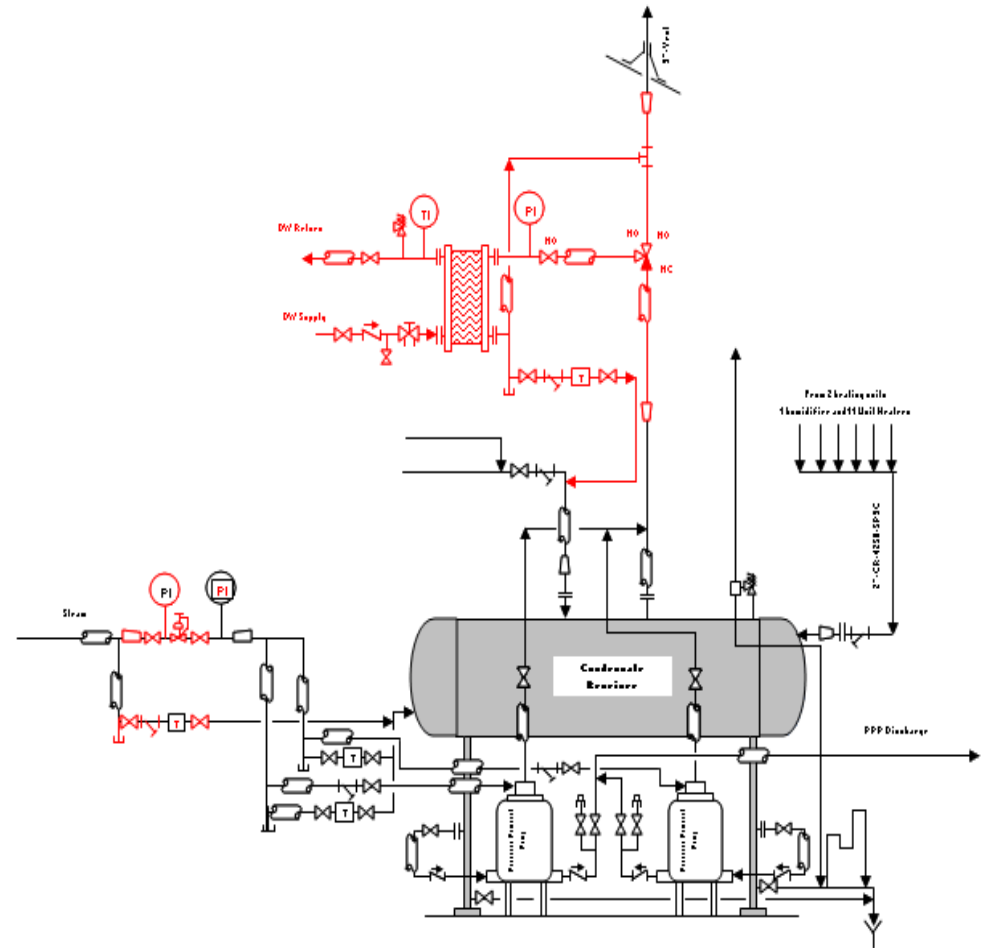

# \$63K Savings Potential

Page Number 7

Recommendation	
Item	Explanation
Evaluate Flash Recovery after trap replacement	Currently, all of the existing condensate return lines enter into one central "master" condensate return tank that feeds the DA tank. This return tank is maintained at a 5-psig pressure via a backpressure regulator. Consideration needs to be given on the impact of the back pressure created on the return system w/associated drainage impact to process users compared to the additional losses of allowing the return tank to flash to atmospheric conditions with out the use of a back pressure regulator. Utilizing atmospheric flash steam to pre-heat boiler make up water should be strongly considered as part of this evaluation
Locations	
Building 15 basement level	
Savings Potential	
\$ 63 K Assume a flash rate of 1,000 #/s/hr (Condensate return 17,500 #/hr with a 8.9 % flash is ~ 1,500 #/s/hr)	

# Steam System Optimization

## Flash Recovery Project –Results

**Capital Cost = \$290,000**

### Benefits

- Fuel savings – sensitivity analysis
- Water savings = 18,000,000 gal/year
- Chemical savings

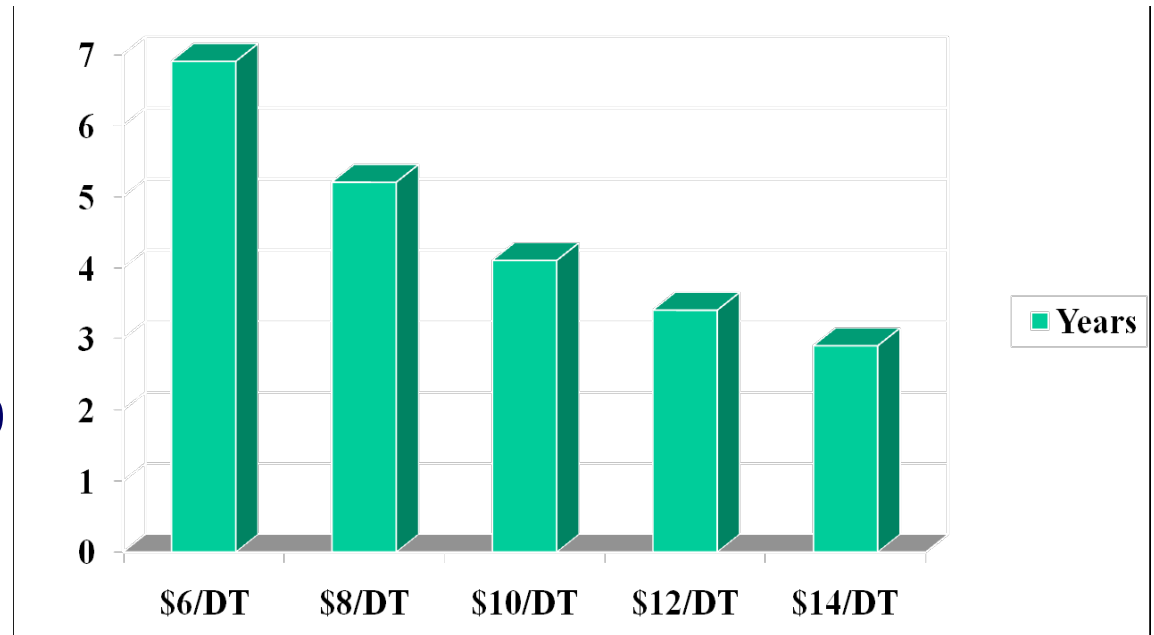

# Steam System Optimization

Process Inefficiency

# Steam System Optimization

Identify and eliminate Improper Piping Practices



**Non-Best Practice Piping to Agglomerator**

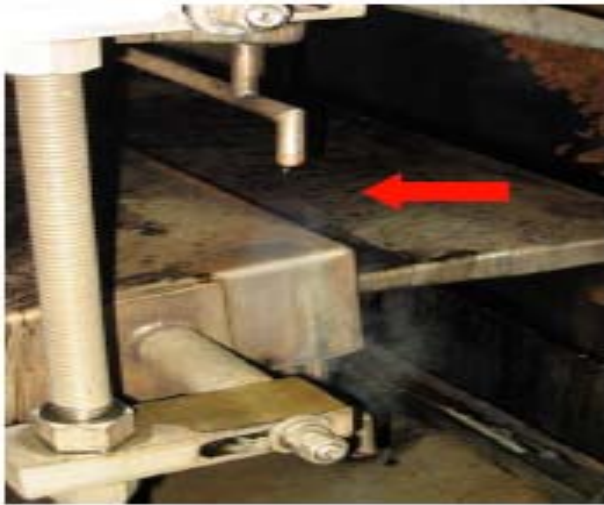

**Steam venting to keep Agglomerator dry**



**Rice Steam supply w/ no trap, separator or filter**



# Steam System Optimization

## Steam User / Process Efficiency Study

### Clean Steam for Humidification?

- Less the 5 years old
- Building seats 23,000 people
- 11 Clean Steam Generators
- AHU contamination



# Steam System Optimization

Steam User / Process Efficiency Study

New Clean Steam Humidification System:

- Controlled at 30% RH
- 11 to 5 Clean Steam Generators Pkg. w/Feedwater Filtration (properly sized)
- SS Clean Steam Distribution Piping
- SS Steam Humidifiers



# System Improvements



TRAINING

# Spirax Sarco Training Courses

## **Introduction to Fundamentals**

## **Installation and Maintenance**

- Steam Traps and Condensate Pumps
- Pressure and Temperature Control Systems

## **Engineering and Design**

- Steam System Design
- Advanced Steam System Design

## **Columbia**

1150 Northpoint Blvd  
Blythewood, SC 29016

Suite 600  
Lisle, IL 60532

## **Houston**

203 Georgia Avenue  
Deer Park, TX 77536

## **Chicago**

1500 Eisenhower Lane

## **Workshops**

- Condensate Recovery Workshop
- Pressure and Temperature Control Workshop
- Boiler Room, Level Control and Metering Workshop

## **Specialty Courses**

- Steam Utilization for HVAC Applications
- Steam Utilization in Universities
- Clean Steam Utilization
- Steam Utilization in the Hospital Industry

## **Allentown**

4647 Saucon Creek  
Road  
Suite 102

Center Valley, PA  
18034